

Vanguard

the all-round anti-climb guard



Attractive - effective - affordable

With crime and vandalism an ever increasing threat, protecting your property from theft and serious damage is now a priority for business and domestic premises alike.

Vanguard offers a practical solution by providing an effective, very difficult to negotiate anti scale barrier, with minimal risk of potential intruders impaling themselves should they fall onto it, thus minimising your risk of potential prosecution under owner occupiers liability legislation.

Vanguard installed above a wall to prevent intruders scaling a perimeter wall

Vanguard installed beneath guttering to protect against intruders climbing onto a flat or pitched roof



above a wall

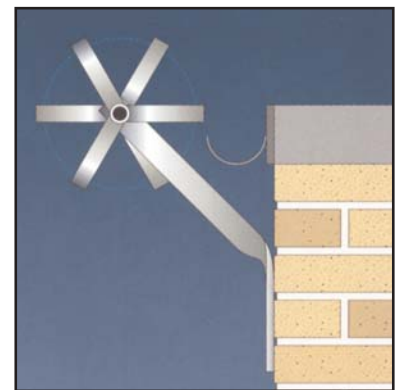

installed beneath guttering

Vanguard installed above palisade fencing - support brackets fix to the palisade uprights.

The versatile brackets allow the vanguard barrier to be cranked outwards (as shown right) or inwards.

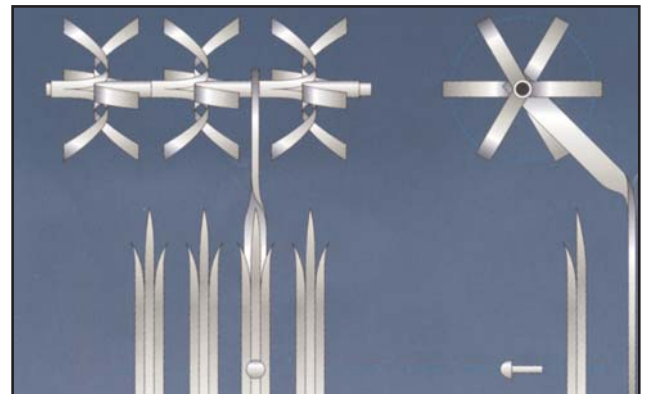

Vanguard installed over a palisade fence

The ideal solution for a wide range of applications;

- Fences, walls, gates, steel palisades
- Commercial, industrial and domestic premises
- Car parks
- Sports & leisure areas
- Schools & local authority grounds
- Electricity pylons, CCTV camera poles / towers
- Drain pipes, soil stacks, etc.

.....and many more applications

Construction and operation

Vanguard incorporates a unique and clever design consisting of a series of curved vanes, each revolving freely around a central shaft to create an unstable barrier which moves if anyone attempts to climb over it.

Strong, durable and corrosion resistant, Vanguard has a long lifespan so will be protecting your property for years to come.

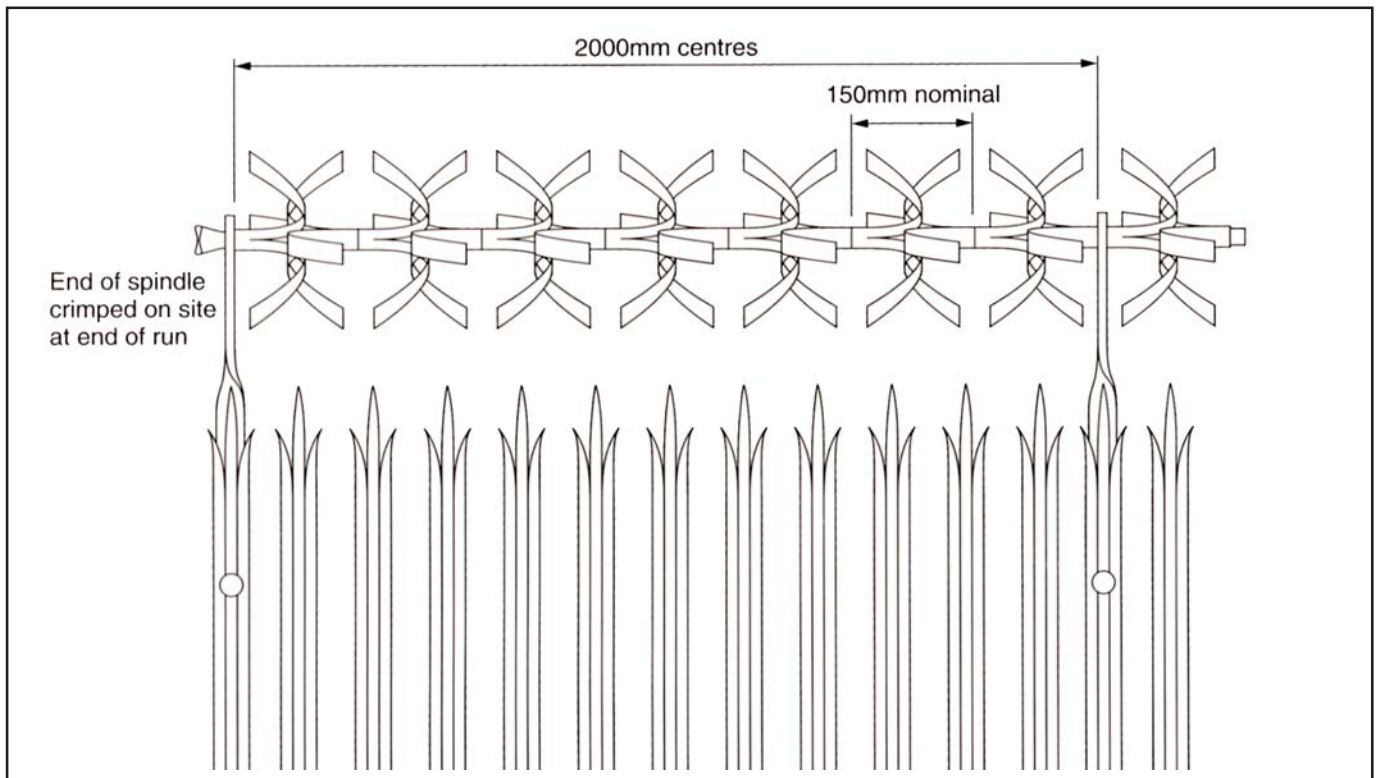

Technical Specifications

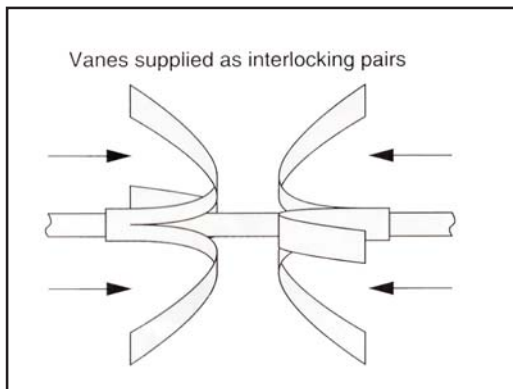

Description:

A freely rotating anti-scaling obstacle manufactured from high tensile alloy tube and assembled to form six vanes per element.

Specification:

Aluminium vanes extruded alloy BS6082 T4: OD 31.75mm x 2.5mm

Nominal weight; 0.173kg each

Overall diameter of assembled elements; approx 400mm

Colours; Natural (can be polyester colour coated at extra cost)

Spindle

Extruded round tube BS1471: 1986 (BS6082) OD: 25mm x 2mm

Supports

Dimensions; 40mm x 8mm

Mild steel or aluminium twice drilled to receive M8 fixing bolts

Choice of finish to customer specification. Galvanised as standard or natural coated (supplementary cost)

Applications

All situations where theft or serious vandalism is likely and particularly where Public Liability legislation applies. Also in environmentally sensitive areas where an inoffensive appearance is important. Examples include commercial and industrial sites, schools, vehicle parking areas, domestic premises, sports and leisure areas.

Fixing:

Vanguard can either be bolted to walls using expandable through bolts or clamped or welded to fences and gates. Stanchions should be adjusted to support Vanguard centrally over the wall or fence with a clearance not exceeding 50mm in order to eliminate any stable platform or foothold.

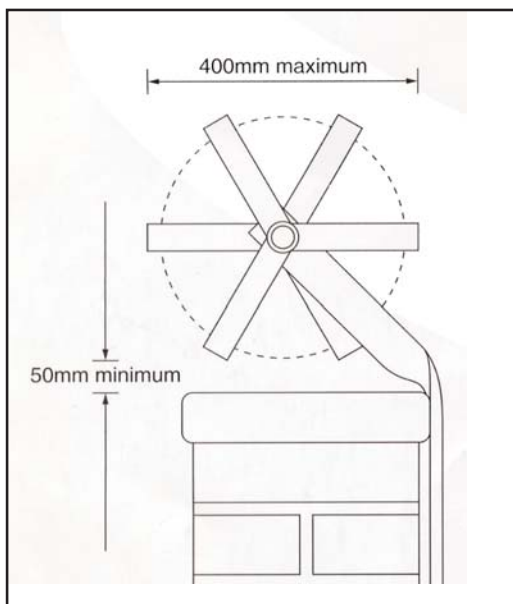

your local distributor is:

Insight Security

Unit 2, Cliffe Industrial Estate
Lewes, East Sussex, BN8 6JL

tel: 01273 475500 fax: 01273 478800

www.insight-security.com